

BOOSTER



CHEM



EXTRU



PURO



POLY



BOOSTER

Gear pump for polymer processing

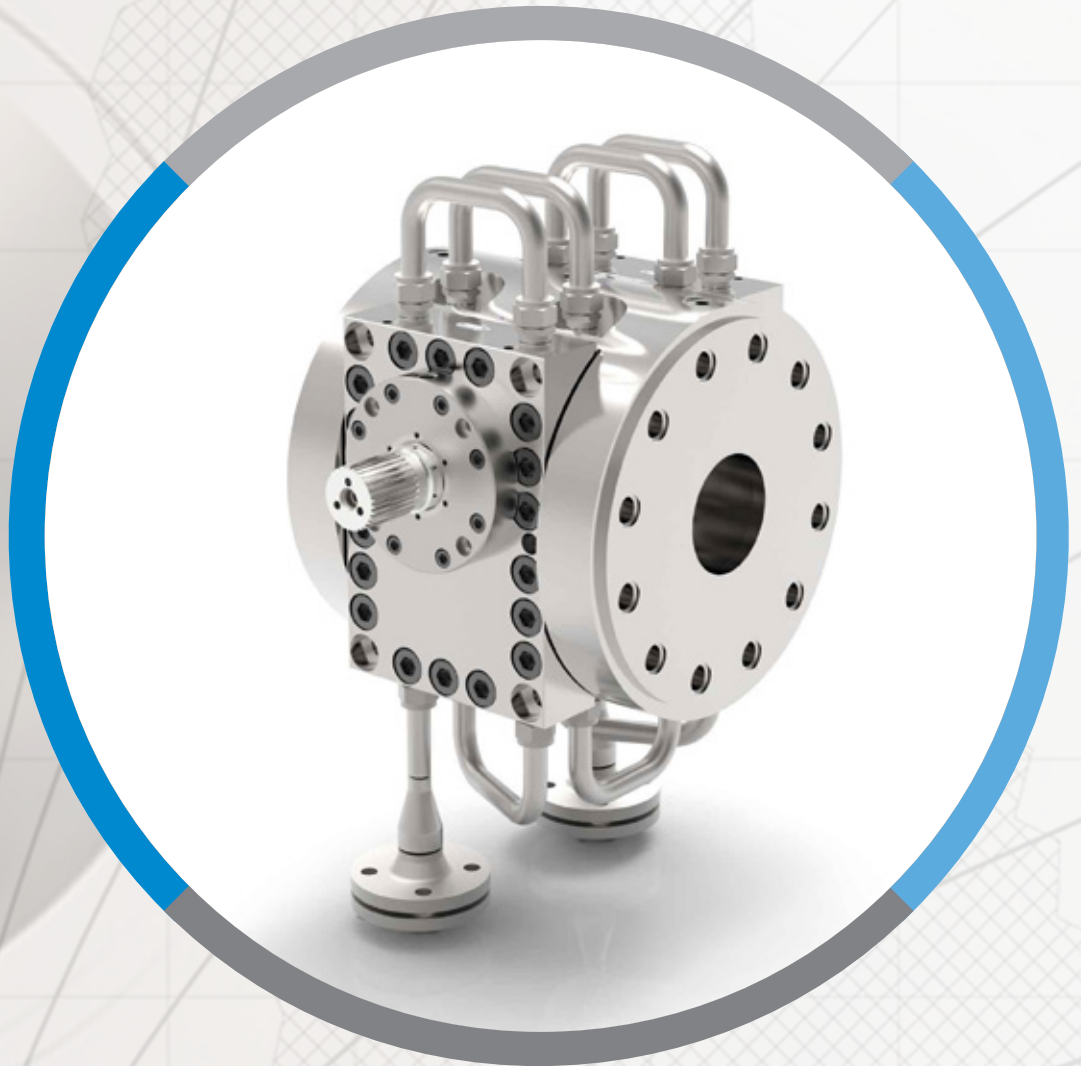

BOOSTER

The reliable transfer and booster gear pump for polymer processing
Gear pumps are used in the polymerization process, to boost the pressure of medium to high viscosity media. They transport pre-polymers and polymers, e.g. PET, PBT, PS, ABS and many more, very gently Heating is either by way of heat transfer oil or steam. The core components like shafts and friction bearings originate from the WITTE building block system.

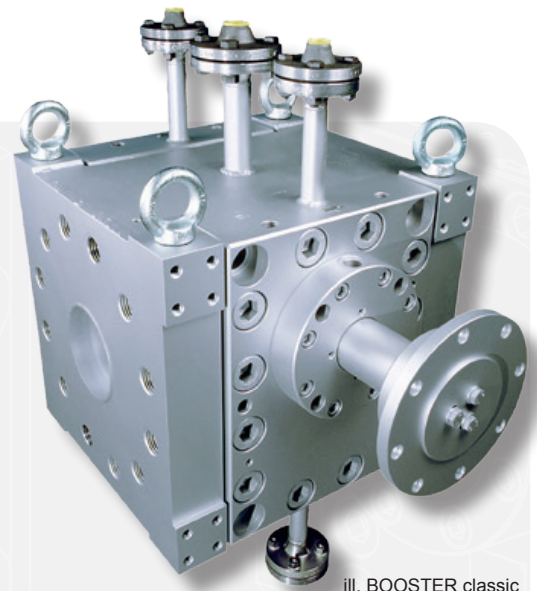

ill. BOOSTER classic

Technical Features

Housing:	Heat resistant carbon steel, e.g. 1.6582 (4340), stainless steel e.g. 1.4313 (E415) optional: coating
Gears:	Tool steel, nitrited steel, optional: special steel, surface coating, helical gearing herringbone gearing (for extremely low-pulsation conveyance)
Friction Bearings:	Tool steel, Al-bronze, NiAg (nickel-silver), special materials optional: surface coating
Shaft Seal:	Viscoseal, vacuum viscoseal, stuffing box
Heating Systems:	Heat transfer oil, steam

Application Examples

Polymers: PET, PBT, PA, PC, PS, SAN, ABS, HIPS, PP, PE, POM, Biopolymers

Pump Sizes

From 22/22 (4,7 cm³/rev) up to 280/280 (12.000 cm³/rev).

Operating Parameters

Viscosity:	Up to max. 40.000 Pas
Temperature:	Up to max. 350 °C (662 °F)
Suction Pressure:	Vacuum up to max. 120 bar (1.740 psig)
Differential Pressure:	Up to max. 250 bar (3.626 psig)

The values listed are maximum values and must not coincide under certain circumstances.

Seals / Applications

Seals

Viscoseal (VS)

The viscoseal is the standard seal for WITTE EXTRU and BOOSTER pumps. This is a dynamic seal for high viscosities and suction pressures. It can be provided with heating or cooling. The dynamic seal is suitable for high pressures and temperatures. Its range of use is limited by the suction pressure and the viscosity of the medium being conveyed (at least 50 Pas). The viscosity can be increased by an additional cooling system if necessary.

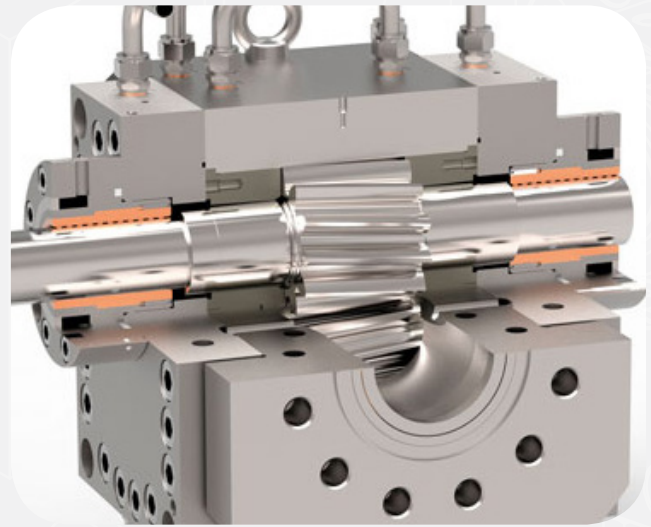

Viscosity:

50 to 40.000 Pas

Temperature:

max. 350 °C (662 °F)

Viscoseal (VS) with stuffing box

The stuffing box can be used as an additional seal for the viscoseal. The stuffing box is a simple (static) seal for WITTE gear pumps. It can be provided with buffering if so desired. The range of application is similar to that of the viscoseal. The standard material used for the packing is made of expanded pure graphite with structural textile fibers. But it goes without saying, that other materials are also available.

Viscosity (stuffing box):

max. 10.000 Pas

Temperature:

max. 350 °C (662 °F)

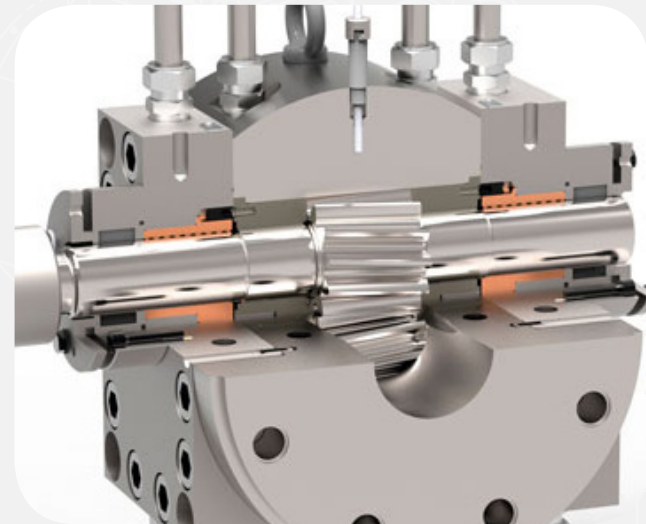

Applications

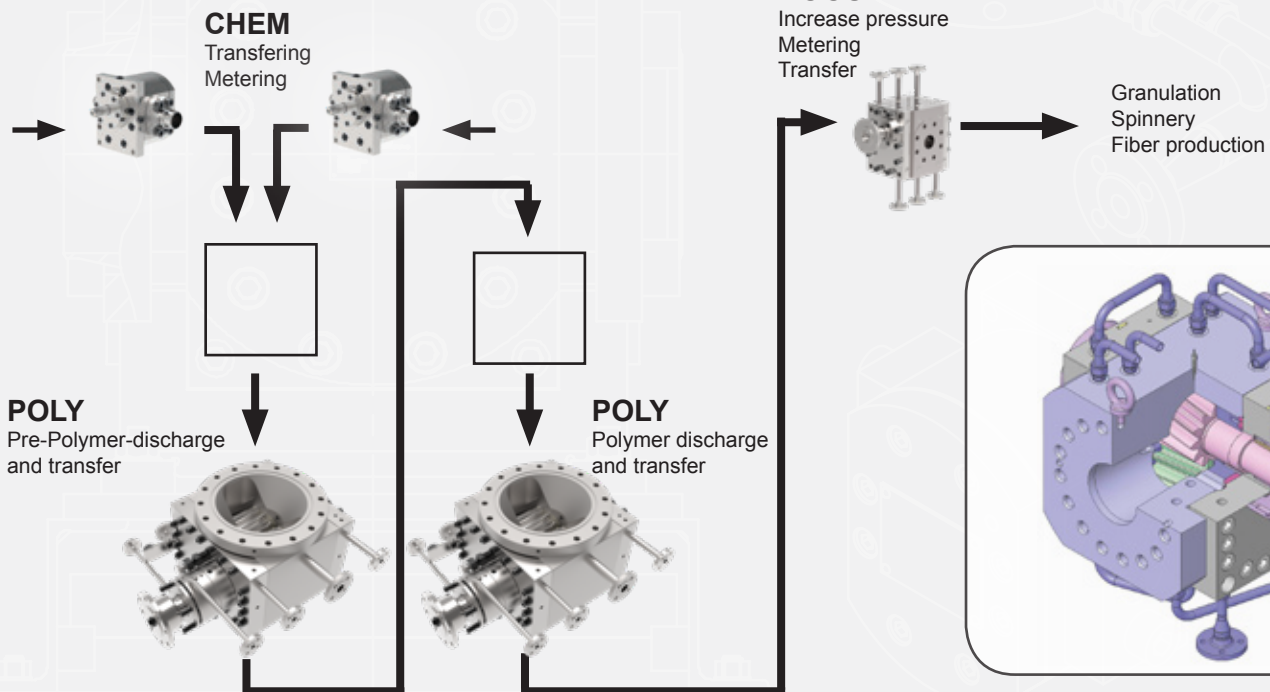

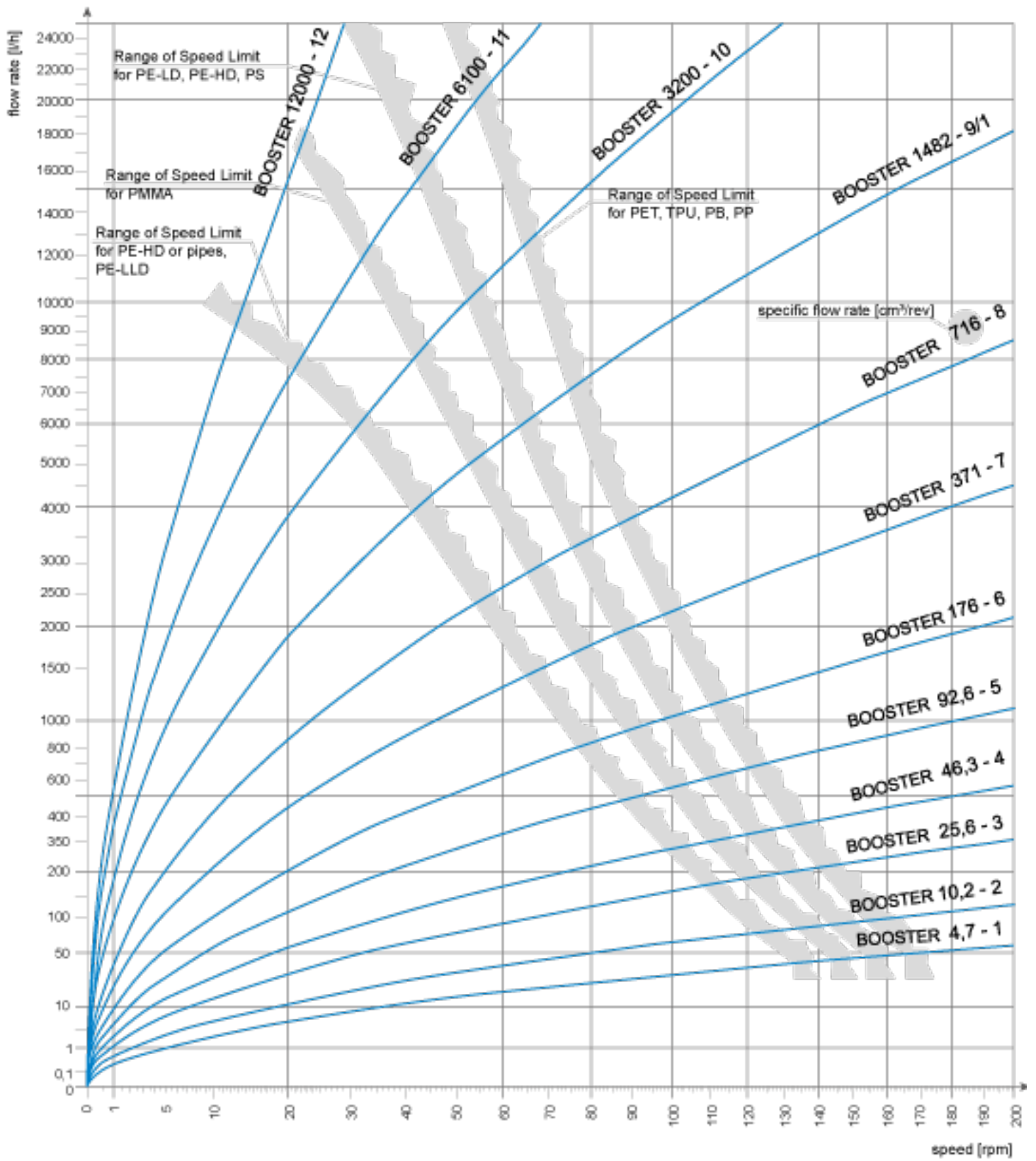

Size / Capacity / Displacement Volume

Pump Sizes

Size	Spec. displacement volume (cm ³ /rev)	Capacity (l/h)*
1 (22/22)	4,7	3 - 56
2 (28/28)	10,2	6 - 92
3 (36/36)	25,6	15 - 230
4 (45/45)	46,3	28 - 417
5 (56/56)	92,6	55 - 722
6 (70/70)	176	105 - 1370
7 (90/90)	371	222 - 2890
8 (110/110)	716	430 - 4700
9 (140/140)	1.482	900 - 8850
10 (180/180)	3.200	1920 - 17000
11 (224/224)	6.100	3660 - 32000
12 (280/280)	12.000	6590 - 58000

* (Depending on the fluid characteristics and operating conditions)

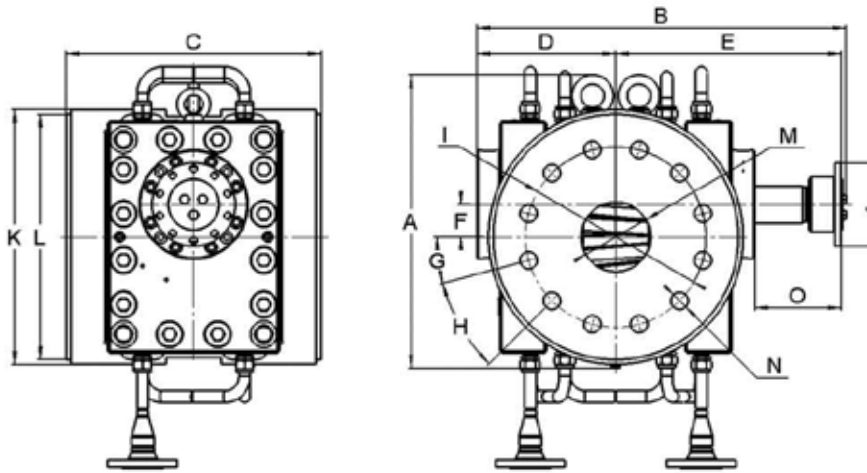

BOOSTER-Dimensions

Pump size	A	B	C	D	E	F	G	H	I	J	K	L	M	N	O	Weight
1 (22/22)	99,6	142,1	100	48	90	11	22,5	8x45	66	58	92	84	28	8xM8	40,5	6 Kg
2 (28/28)	134,9	173	135	59	109	14	22,5	8x45	90	65	116	108	32	8xM10	50	15 Kg
3 (36/36)	185,9	215	150	76	134	18	22,5	8x45	110	75	145	136	42	8xM12	58	20 Kg
4 (45/45)	235,9	316,7	204	104,5	203,5	22,5	22,5	8x45	750	90	195	185	55	8xM16	99	50 Kg
5 (56/56)	281,5	368	230	120	239	28	22,5	8x45	185	100	230	218	68	8xM20	119	80 Kg
6 (70/70)	350,4	430,8	260	145	276	35	22,5	8x45	235	120	290	275	80	8xM24	131	150 Kg
7 (90/90)	430,4	505,3	335	181	312	45	15	12x30	300	150	362	346	100	12xM24	147	280 Kg
8 (110/110)	495,9	563	420	215	335	55	15	12x30	340	180	430	400	125	12xM30	120	500 Kg
9 (140/140)	620	800	550	300	485	70	15	12x30	390	225	550	530	150	12xM39	235	1000 Kg
10 (180/180)	817	1040	680	418	617	90	11,25	16x22,5	440	250	700	680	200	16xM39	297	1830 Kg

WITTE WORLDWIDE

WITTE PUMPS & TECHNOLOGY GmbH
Tornesch, Germany

OOO WITTE PUMPS & TECHNOLOGY
Moscow, Russia

WITTE PUMPS & TECHNOLOGY
Shanghai Ltd., China



WITTE PUMPS & TECHNOLOGY LLC
Lawrenceville, GA, USA

WITTE PUMPS & TECHNOLOGY
Kuala Lumpur, Malaysia

WITTE PUMPS & TECHNOLOGY GmbH
Lise-Meitner-Allee 20
D-25436 Tornesch / Hamburg / Germany

P: +49 (0) 4120 70659-0
F: +49 (0) 4120 70659-49
info@witte-pumps.com
www.witte-pumps.com

WITTE  [®]
PUMPS & TECHNOLOGY